

## Description

These devices are monolithic timing circuits capable of producing accurate time delays or oscillation. In the time delay mode of operation, the timed interval is controlled by a single external resistor and capacitor or network. In the astable mode of operation, the frequency and duty cycle may be independently controlled with two external resistors and a single external capacitor.

## Features

- Timing from Microseconds to Hours
- Astable or Monostable Operation
- Adjustable Duty Cycle
- TTL - Compatible Output Can Sink or Source Up to 200 mA
- Temperature Stability of 0.005% per °C
- Direct Replacement for Signetics NE555 Timer



DIP-8



SOP-8

## Package

## Applications

- Precision timing
- Pulse generation
- Sequential timing
- Time delay generation
- Pulse width modulation
- Pulse position modulation
- Missing pulse detector

## Pin Configuration

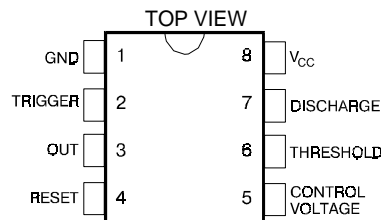

## Internal Block Diagram

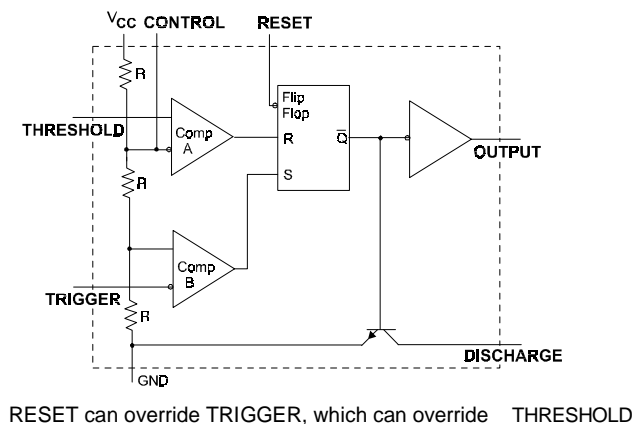

## Absolute Maximum Ratings

( $T_A=25^\circ\text{C}$ , unless otherwise specified)

Parameter	Min	Max	Units
Supply Voltage, $V_{CC}$	4.5	16	V
Input Voltage (control, reset, threshold and trigger)		$V_{CC}$	
Output Current, $I_O$		$\pm 200$	mA
Operating Free-Air Temperature, $T_A$		70	$^\circ\text{C}$
Storage Temperature Range, $T_{STG}$	-65	+150	

## Electrical characteristics

( $T_A=25^\circ\text{C}$ ,  $V_{CC}=+5\text{V}$  to  $+15\text{V}$ , unless otherwise specified)

Parameter	Test conditions (Note 2)	Min	Typ	Max	Units
Operating Supply Voltage Range		4.5		16	V
Threshold Voltage Level	$V_{CC}=15\text{V}$	8.8	10	11.2	V
	$V_{CC}=5\text{V}$	2.4	3.3	4.2	
Threshold Current (Note 1)	(see Note 1)		30	250	nA
Trigger Voltage Level	$V_{CC}=15\text{V}$	4.5	5	5.6	V
	$V_{CC}=5\text{V}$	1.1	1.67	2.2	
Trigger Current	Trigger at 0V		0.5	2	$\mu\text{A}$
Reset Voltage Level		0.3	0.7	1	V
Reset Current	Reset at $V_{CC}$		0.1	0.4	mA
	Reset at 0V		-0.4	-1.5	
Discharge Leakage Current			20	100	nA
Control Voltage Level	$V_{CC}=15\text{V}$	9	10	11	V
	$V_{CC}=5\text{V}$	2.6	3.3	4	
Low-level Output Voltage	$V_{CC}=15\text{V}$	$I_{OL}=10\text{mA}$		0.1	0.25
		$I_{OL}=50\text{mA}$		0.4	0.75
		$I_{OL}=100\text{mA}$		2	2.5
		$I_{OL}=200\text{mA}$		2.5	
	$V_{CC}=5\text{V}$	$I_{OL}=5\text{mA}$		0.25	0.35
		$I_{OL}=8\text{mA}$		0.3	0.4
High-level Output Voltage	$V_{CC}=15\text{V}$	$I_{OL}=-100\text{mA}$	12.75	13.3	
		$I_{OL}=-200\text{mA}$		12.5	
	$V_{CC}=5\text{V}$	$I_{OL}=-100\text{mA}$	2.75	3.3	
Supply Current	Output Low, No Load	$V_{CC}=15\text{V}$		10	15
		$V_{CC}=5\text{V}$		3	6
	Output High, No Load	$V_{CC}=15\text{V}$		9	13
		$V_{CC}=5\text{V}$		2	5
Initial Error of Timing Interval (Note 3)	monostable (Note 4) astable (Note 5)	$T_A=25^\circ\text{C}$		1	3
				5	13
Temperature Coefficient of Timing Interval	monostable astable	$T_A=\text{MIN to MAX}$		50	150
				150	500
Supply Voltage Sensitivity of Timing Interval	monostable astable	$T_A=25^\circ\text{C}$		0.1	0.5
				0.3	1
Output Pulse Rise Time		$C_L=15\text{pF}$ , $T_A=25^\circ\text{C}$		100	300
Output Pulse Fall Time					100

Note 1: This parameter influences the maximum value of the timing resistors  $R_A$  and  $R_B$  in the circuit on Fig 1. For example, when  $V_{CC}=5\text{V}$ , the maximum value is  $R=R_A+R_B=3.4\text{ M}\Omega$ , and  $V_{CC}=15\text{V}$ , the maximum value is  $10\text{ M}\Omega$ .

Note 2: For conditions shown as MIN or MAX, use the appropriate value specified under recommended operating conditions.

Note 3: Timing interval error is defined as the difference between the measured value and the average value of a random sample from each process run.

Note 4: Values specified are for a device in a monostable circuit similar to Fig. 2, with component values as follow:  $R_A=2\text{K}\Omega$  to  $100\text{ K}\Omega$ ,  $C=0.1\mu\text{F}$ .

Note 5: Values specified are for a device in an astable circuit similar to Fig. 1, with component values as follow:  $R_A$ ,  $R_B=1\text{K}\Omega$  to  $100\text{ K}\Omega$ ,  $C=0.1\mu\text{F}$ .

## Function Table

Reset	Trigger Voltage *	Threshold Voltage *	Output	Discharge Switch
Low	Irrelevant	Irrelevant	Low	On
High	$< 1/3 V_{CC}$	High	High	Off
High	$> 1/3 V_{CC}$	$> 2/3 V_{CC}$	Low	On
High	$> 1/3 V_{CC}$	$< 2/3 V_{CC}$	As previously established	

\* Voltage levels shown are nominal

## Typical Applications Circuit

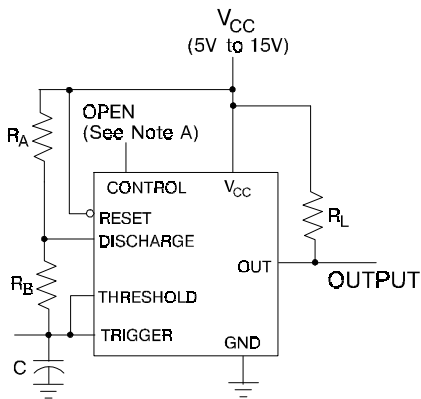

Figure 1 Circuit for astable operation

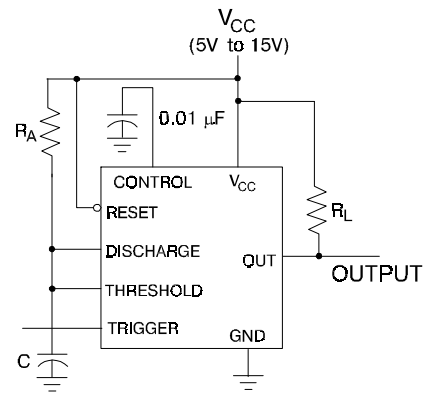

Figure 2. Circuit for monostable operation

NOTE A: Bypassing the control voltage input to ground with a capacitor may improve operation. This should be evaluated for individual

## Ordering Information

ORDERING NUMBER	PACKAGE	MARKING
NE555	DIP - 8 / SOP - 8	NE555

Address : 北京市海淀区永定路 88 号长银大厦 6A06--6A07

Rm 6A07, Changyin Office Building ,No.88, Yong Ding Road, Hai Dian District , Beijing

Postalcode: 100039

Tel: 86-010-58895780 / 81 / 82 / 83 / 84 Fax : 010-58895793

Http://www.estek.com.cn

Email:sales@estek.com.cn

REV No:01-060823